

RX20
SERIES

66-73 HP

UTILITY TRACTORS



Powerful Performance, Exceptional Value



RX20 SERIES

BUILT FOR RURAL LANDOWNERS WHO DEMAND STRENGTH AND RELIABILITY FOR EVERY TASK

The RX20 Series is engineered to deliver outstanding performance and exceptional value for farmers, ranchers, and rural landowners alike. With robust power and dependable engineering, these tractors make hauling hay, working the fields, and handling tough jobs easier than ever. Discover why the RX20 Series is the trusted choice for those who demand strength, reliability, and lasting value for their land.

**WE DIG
DIRT**

- KIOTI 4-Cylinder In-Line Vertical, Water-Cooled Turbo Diesel Engine
- 66 - 73 HP
- Power Shuttle or Power Shuttle with Creeper Transmission
- Torque Compensation
- 3-Point Hitch with Telescopic Lower Links & Stabilizers
- Up to 3,898 lb. (1,768 kg), 3-point lift capacity
- 540 / 540E PTO
- Hydrostatic Power Steering with Tilt
- Spacious Cab w/Panoramic Views
- Climate Control System

RX20 SERIES

PERFORMANCE FEATURES BUILT TO DOMINATE

Fuel Efficient Diesel Engine

KIOTI 4-Cylinder in-line vertical, water-cooled turbo diesel, CRDI engine improves fuel efficiency while reducing noise levels. It provides the operator with a quiet work environment and powerful performance.

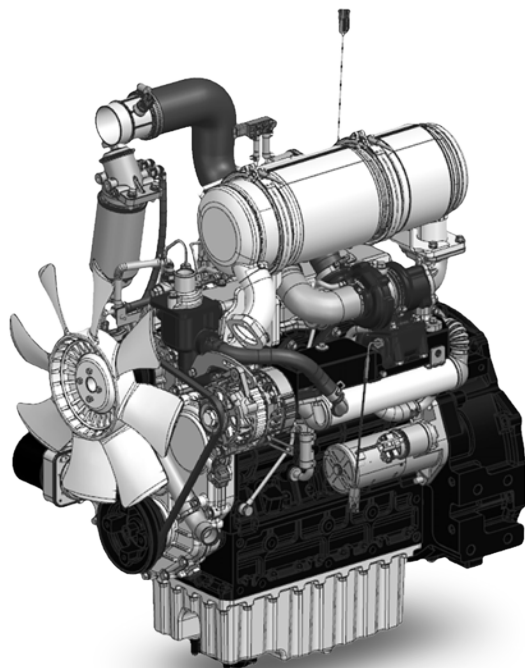

Proven Quality and Performance

KIOTI engines are known for exceptional performance and fuel efficiency. Backed by over 65 years of innovation, they meet rigorous global standards like EPA, CARB, and EEC certifications. Built for reliability and durability, these engines are a trusted choice for a wide range of demanding applications.



Deluxe Cab

The large cab design offers exceptional visibility to every corner of the field. Expansive windows and ample headroom create a comfortable and spacious environment, boosting your productivity and ease of operation.



Powerful Lift Capacity

Delivers an impressive 3-point lift capacity of up to 3,898 pounds (1,768 kg), built to handle heavy implements and demanding jobs with ease and reliability.



Two Transmission Options

The RX20 Series gives you the power of choice with two advanced transmission options. The 12×12 power shuttle makes direction changes smooth and effortless—no clutching required. For even greater versatility, the 24×24 power shuttle with creeper delivers a broader range of speeds, including ultra-slow settings for precision work.



Climate Control System

Offers optimal temperature control, keeping operators cool in the summer and warm in the winter, ensuring comfort, focus, and productivity all year round.



Remote Hydraulic Valves and Joystick

A standard single-lever joystick provides easy loader or front implement operation. A standard single remote valve (additional valves optional) accommodates a wide variety of attachments and implements.



Push Button Four-Wheel Drive

4WD is engaged with the simple push of a button. Auto 4WD engagement allows for increased braking performance.



Power Shuttle Lever (Power Shuttle Models)

The Power Shuttle Lever allows quick and easy shifting between forward and reverse, all without the need to press the clutch pedal.

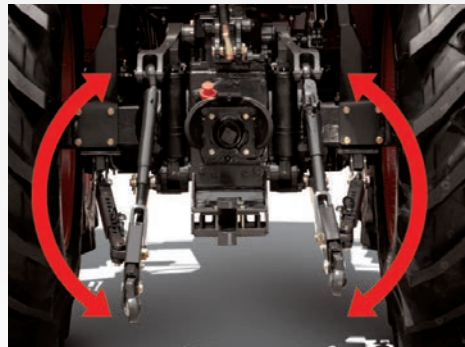

External Hydraulic Lift Cylinder

Two external hydraulic lift cylinders make maintenance easier and increase 3-point lift capacity to 3,594 pounds (66 hp models) and 3,898 pounds (73 hp models).



Hydraulic Independent PTO

The rear PTO engages at the push of a button for independent operation. All models offer selectable manual or Auto PTO, which automatically shuts off when the 3-point hitch control is raised—enhancing safety and efficiency.



Rear Differential Lock

Maximize traction in tough conditions. The rear differential lock forces both rear wheels to rotate at the same speed for enhanced power and control.



RX20 SERIES

COMFORT AND CONVENIENCE FEATURES THAT REDUCE STRESS



Wet Multi-Disc Brakes

Experience superior stopping power, enhanced durability, and low maintenance with wet disc brakes, ensuring reliable, long-lasting performance in the toughest conditions.

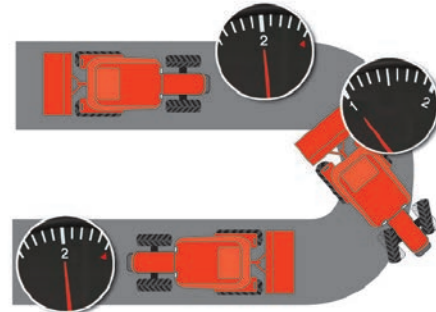

Turn Assist Control (Optional)

The optional Turn Assist Control automatically reduces engine rpm by 10% during sharp turns, simplifying operation and enabling more precise work while reducing fuel consumption.



High Fuel Capacity

The 22-gallon (ROPS) to 25-gallon (Cab) fuel tank lets you power through productive hours without interruption. Stay informed with a fuel indicator lamp on the instrument panel and a buzzer to help prevent accidentally running out of fuel.



Power Steering with Tilt

Minimizes the effort required to make tight, repetitive turns. The steering wheel tilts with the simple push of a lever, allowing easy adjustment to fit the operator's needs.



Creeper Gear (RX7320 PCC)

The Creeper Gear delivers exceptional speed control for tasks demanding high PTO power at slow ground speeds, ensuring precision and optimal performance.



Draft Control

Automatically adjusts implement depth to maintain a consistent load, boosting productivity, ensuring optimal traction, minimizing operator effort, and maximizing fuel economy.



KIOTI Connect Capable

KIOTI Connect is an intuitive app that provides real-time insights, maintenance tracking, and remote diagnostics, keeping you connected to your machine like never before.



Rugged Design

Built to endure tough conditions, the KIOTI RX20 series combines heavy-duty construction, powerful engines, and superior durability for demanding tasks.





INCREASED PRODUCTIVITY

Improved performance, work faster & more efficiently



IMPROVED EFFICIENCY

Controls within easy reach for convenience



ENHANCED CABIN COMFORT

Work all day in comfort



RX20
SERIES

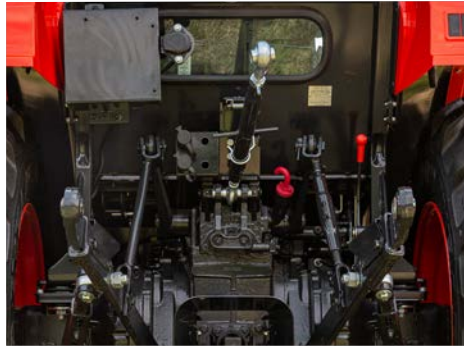

Category II 3-Point Hitch

Offers robust strength, easy attachment, and reliable performance, making it ideal for heavy-duty implements and demanding tasks.



PTO Cruise Control

With one touch, engine speed can be set to maintain a steady RPM for maximum working efficiency. Once engaged, operators can easily adjust RPM up or down with a simple switch.



Projection Head and Working Lamps

Projection head and work lamps provide a broad, bright beam that keeps your field visible for safe, confident operation even after sunset.



Deluxe Suspension Seat

The ergonomically designed, fully adjustable suspension seat cradles you in support, no matter how harsh the ride. A handy pocket on the back of the seat gives you instant access to the operator's manual.



LED Instrument Panel

The instrument panel provides critical information at a glance, including PTO engagement, vehicle information, fuel level, notifications, and alerts.



Fast Traveling Speeds

Increased traveling speeds of up to 22 mph (38 km/h) help you get your work done faster.



Window Wiper

Standard wipers (rear optional) keep your view crystal clear, battling both rain and dust. Their optimized placement ensures the operator's vantage point stays uncompromised.

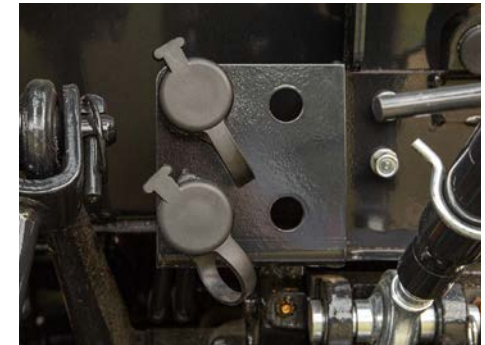

Optional Hydraulic Valves

Optional 2nd and 3rd hydraulic valves expand your tractor's versatility, giving you the power to operate multiple implements with greater efficiency and control.



ATTACHMENTS

BACKHOE (RX6620 ONLY)

The KIOTI KB2485 Series backhoe lets you trench up to 94.4" deep with a bucket dig force up to 3,748 pounds. The KB2485 backhoe features subframe mounting, responsive two-lever controls with exceptional feathering, hydraulic stabilizers, transport lock and a variety of standard and heavy-duty buckets.

BACKHOE SPECIFICATIONS

MODEL		KB2485
Digging Depth (Two Foot Flat Bottom)	in. (mm)	94.4 (2,397.8)
Reach from Center Line of Swing Pivot	in. (mm)	136.1 (3,456.9)
Loading Height (Bucket at 60°)	in. (mm)	80.3 (2,039.6)
Maximum Leveling Angle	deg.	10
Swing Arc	deg.	180
Transport Height (Maximum)	in. (mm)	92.9 (2,359.7)
Transport Overhang	in. (mm)	50.4 (1,280.2)
Bucket Rotation	deg.	180
Stabilizer Spread (Down Position)	in. (mm)	68.7 (1,745.0)
Stabilizer Spread (Up Position)	in. (mm)	46.4 (1,178.6)
Angle of Departure	deg.	21
Shipping Weight (Without Bucket)	lb. (kg)	1,102.0 (499.9)
Bucket Digging Force	lb. (kg)	3,748.0 (1,700.1)
Dipperstick Digging Force	lb. (kg)	2,205.0 (1,000.2)
Operating Pressure	psi (bar)	2,466.0 (170.0)

NOTE: specifications and design are subject to change without notice.

FRONT END LOADER

The KIOTI KL7320 front end loader is specifically designed for the RX20 Series tractors, providing efficient performance with single lever joystick control. The KIOTI loader, with a built-in parking stand, is designed to be quickly and easily attached and detached. KL Series loaders utilize the tractor's hydraulic system, feature single-lever control with float and come with a bucket level indicator.

LOADER SPECIFICATIONS

MODEL		KL7320
Maximum Lift Height to Pivot Pin	in. (mm)	133.9 (3,401.1)
Clearance with Bucket Level	in. (mm)	123.0 (3,124.2)
Clearance with Bucket Dumped	in. (mm)	102.3 (2,598.4)
Reach at Maximum Lift Height	in. (mm)	20.4 (518.2)
Maximum Dump Angle	deg.	47
Reach with Bucket on Ground	in. (mm)	80.4 (2,042.2)
Maximum Rollback Angle	deg.	54
Digging Depth Below Grade	in. (mm)	6.5 (165.1)
Overall Height in Carry Position	in. (mm)	69.3 (1,760.2)
Bucket Depth (Inner Shell)	in. (mm)	23.3 (591.8)
Bucket Height	in. (mm)	22.9 (581.7)
Bucket Length (Pivot Pin)	in. (mm)	33.0 (838.2)
Lift Capacity to Full Height at Pivot Pins	lb. (kg)	3,384.0 (1,535.0)
Breakout Force at Pivot Pins	lb. (kg)	5,359.0 (2,430.8)
Bucket Rollback Force at Ground Line	lb. (kg)	5,029.0 (2,281.1)
Relief Valve Setting (Loader Control Valve)		66 HP: 2,631 psi (185 kg/cm ²) / 73 HP: 2,774 psi (195 kg/cm ²)
Rated Flow (Tractor System)	gpm (L/min)	10.57 (40.0)
Bucket Size Available (QA)	in. (mm)	82.0 (2,082.8)
Bucket Capacity (Heaped)	cu. ft. (m ³)	21.2 (0.6)
Approximate Weight (With Bucket)	lb. (kg)	1,896.0 (860.0)

NOTE: specifications and design are subject to change without notice.

SPECIFICATIONS

MODEL		RX6620PC	RX7320PC	RX7320PCG
ENGINE				
Model		4F243T		
Type		KIOTI 4 Cylinder, In-Line Vertical, Water-Cooled 4-Cycle Turbo Diesel, CRDI		
Engine Gross	HP (kW)	66.0 (49.2)		73.0 (54.4)
PTO	HP (kW)	57.6 (43.0)		63.0 (47.0)
Displacement	cu. in. (cc)	148.6 (2,435.1)		
Rated Revolution	rpm	2,600		
Fuel Tank Capacity	gal. (ℓ)	25.0 (94.6)		25.0 (94.6)
DRIVE TRAIN				
Clutch		Wet Disc		
Transmission		Power Shuttle		Power Shuttle w/ Creeper
Speeds		12Fx12R		24Fx24R
Differential Lock			Rear Standard	
Brake			Wet Multi Disc	
PTO Type			Independent	
Rear PTO (Standard)	rpm		540 / 540 E	
4WD Type			Electric / Hydraulic	
HYDRAULIC SYSTEM				
Pump		Gear		
Pump Capacity (Max flow rate)	gpm (L/min)	17.9 (67.6)		19.2 (72.8)
3-Point Hitch		Category II		
Maximum Lifting Capacity*	lb. (kg)	3,594.0 (1,630.2)		3,898.0 (1,768.1)
Hydraulic Lift Control System		Position with Draft Control		
Number of Remote Valves		1st (2nd, 3rd Optional)		
Steering		Hydrostatic Power Steering		
TIRE SIZE				
Front AG. (Turf, Industrial)		9.5-20 (31x13.5x15/8, 12.5/80-18)		11.2-24 (N/A, 12.5/80-18)
Rear AG. (Turf, Industrial)		14.9-28 (44x18x20/4, 18.4-24/8)		16.9-30 (N/A, 18.4-24/8)
TRAVELING SPEEDS (Max)				
Forward	mph (km/h)	0.94~21.79 (1.51~35.07)	1.01~23.53 (1.63~37.86)	0.11~23.53 (0.17~37.86)
Reverse	mph (km/h)	0.93~21.42 (1.49~34.48)	1.00~23.13 (1.61~37.23)	0.11~23.13 (0.17~37.23)
DIMENSIONS				
Overall Length (incl. 3-pt hitch)	in. (mm)	145.0 (3,685.0)		146.3 (3,716.0)
Overall Width (min. tread)	in. (mm)	70.9 (1,800.9)		77.2 (1,960.9)
Overall Height	in. (mm)	103.6 (2,631.44)		104.5 (2,654.3)
Wheelbase	in. (mm)	82.7 (2,100.6)		83.9 (2,131.1)
Min. Ground Clearance	in. (mm)	16.5 (419.1)		17.3 (439.4)
Tread	Front (AG)	in. (mm)	57.7 (1,465.0)	58.1 (1,475.0)
	Rear (AG)	in. (mm)	55.7 (1,415.0)	59.6 (1,515.0)
Min. Turning Radius (w/ break)	ft. (m)	10.2 (3.1)		11.2 (3.4)
Weight with AG. Tires	lb. (kg)	5,732.0 (2,600.0)		6,162.0 (2,795.0)

* @ 24" aft. of hitch

NOTE: specifications and design are subject to change without notice.

STANDARD EQUIPMENT

- Hydrostatic Power Steering
- Rear Differential Lock
- Rear PTO
- Wet Multi Disc Brakes
- Single Remote Hydraulic Valve
- Joystick Valve
- Adjustable Drawbar
- Adjustable Seat
- Headlights
- Safety Lights
- Front Wiper
- Cup Holder
- SMV Sign
- Parking Brake
- 4 Wheel Drive
- PTO Shield
- Hand Clutch
- Sun Visor
- Side View Mirror
- 7 Pin Socket
- Work Light
- Rear Defrost

OPTIONAL EQUIPMENT

- Second & Third Remote Hydraulic Valves
- Locking Fuel Cap
- Turn Assist
- Front Suit Case Weight
- Rear View Mirror
- CD Player
- Rear Wiper
- 12 V Power Outlet



Daedong - USA, Inc.
KIOTI Tractor Division
 6300 KIOTI Drive, Wendell, NC 27591 USA
 Toll free 877-GO-KIOTI Fax 919-374-5001
 Web www.KIOTI.com

Dealer Imprint Area